

Art. 3214834



**I
T
A
L
I
A
N
O**

Malossi è lieta di presentare le nuove marmitte RX omologate per maxiscooter!

Si tratta di una nuova linea di scarichi omologati, progettati per l'utilizzo su un'ampia gamma di motori (fino a 400 cc).

Un vero concentrato di tecnologia dal peso estremamente ridotto: una marmitta RX pesa soltanto 3.5 kg circa! Una riduzione di peso che può raggiungere addirittura i 3 kg a seconda dell'applicazione!

Parti interne e DB killer completamente riprogettati al fine di raggiungere le migliori prestazioni pur contenendo il rumore entro i limiti normativi, tre silent-block per ridurre le vibrazioni ed estrema semplicità e velocità di montaggio grazie ad una piastra sagomata e a tre attacchi sul silenziatore.

Un altro capolavoro Malossi!!!

**E
N
G
L
I
S
H**

Malossi is pleased to announce the new homologated RX exhaust systems for maxi scooters!

It's a new line of homologated exhausts suitable for a wide range of engines (up to 400 cc).

A genuine concentrate of technology, but a very reduced weight: an RX exhaust weights approximately 3.5 kg only! This weight reduction may even reach 3 kg depending on its application.

Internal components and DB killer were completely re-designed in order to achieve the best performance, but keep the noise within law limits; three silent-blocks allow to reduce vibrations, while a shaped plate and three fasteners on the silencer ensure an easy and quick assembly.

A further Malossi masterpiece!!!

**F
R
A
N
Ç
A
I
S**

Malossi est heureuse de présenter les nouveaux pots RX homologués pour maxi scooter !

Il s'agit d'une nouvelle ligne d'échappements projetés pour être utilisé sur une grande gamme de moteurs (jusqu'à 400 cc).

C'est un vrai concentré de technologie de poids extrêmement bas : un pot RX pèse seulement 3.5 kg à peu près ! Une réduction de poids qui peut même atteindre 3 kg selon l'application !

Pièces intérieures et DB killer projetés complètement à nouveau pour atteindre les meilleures performances en limitant le bruit dans le limite normatif ; trois silent-block pour réduire les vibrations et une grande simplicité et vitesse de montage grâce à une plaque profilée ainsi qu'à trois fixations sur le silencieux.

Un autre chef-d'œuvre Malossi !!!

Caratteristiche tecniche

- Omologazione europea
- Silenziatore, collettore e staffa in lega di acciaio inox
- Fondello in carbonio
- Satinatura superficiale
- Peso ridotto a circa 3.5 kg
- Marchio Malossi marcato a laser
- Montaggio facilitato grazie ad una piastra sagomata e a tre attacchi sul silenziatore
- Parti interne e DB killer completamente riprogettati
- Riduzione delle vibrazioni e degli shock dal forcellone grazie alla presenza di tre silent-block

Technical details

- European homologation
- Silencer, manifold and bracket in stainless steel alloy
- Carbon bottom plate
- Satin finish
- Weight reduction to about 3.5 kg
- Laser marked Malossi logo
- Easy assembly thanks to a shaped plate and three fasteners on the silencer
- Internal parts and DB killer entirely re-designed
- Reduced vibrations and shocks from the swing arm thanks to three silent-blocks

Caractéristiques techniques

- Homologation Européenne
- Silencieux, échappement et plaque en alliage d'acier inox
- Culot en carbone
- Satinage superficiel
- Poids réduit à peu près 3.5 kg
- Logo Malossi marqué au laser
- Montage facilité grâce à une plaque profilée et trois fixations sur le silencieux
- Pièces intérieures et DB killer complètement projetées à nouveau
- Réduction des vibrations et des chocs par le bras oscillant grâce à la présence de trois silent-block



E' VIETATA ogni modifica o manomissione dell'impianto di scarico. Qualora eseguita la Malossi declina ogni responsabilità derivante da vizi, difetti e cattivo funzionamento del prodotto manomesso o modificato.

OPERAZIONI PRELIMINARI

Prima di effettuare qualsiasi operazione accertarsi che la temperatura superficiale del blocco motore e dell'impianto di scarico sia tale da non procurare danni all'operatore e/o alle parti non resistenti al calore (carene, tubazioni, guaine, ecc.)



IT IS FORBIDDEN to make any modifications to exhaust system. Whatever form this may take, Malossi declines any responsibility for defects, problems, or malfunction arising from the use of any product which has been modified or tampered with.

PRELIMINARY OPERATIONS

Before carrying out any work on the machine or its exhaust, ensure that the temperature of the power unit and the exhaust will cause no harm either to the operator or to parts which are not heat resistant (such as fairing, hoses, sleeves, etc.)



IL EST ABSOLUMENT INTERDIT de modifier l'échappement. Dans le cas contraire, Malossi décline toutes responsabilités.

OPERATIONS PRELIMINAIRES

Avant d'effectuer toute opération, vérifier que le pot d'échappement est froid afin d'éviter toute brûlure et toute détérioration aux pièces (carénage, tubes, gaines, etc.).

ISTRUZIONI DI MONTAGGIO

- Rimuovere lo scarico originale
- Montare la staffa di sostegno sul terminale Malossi utilizzando la bulloneria fornita nel kit come mostrato in figura
- Innestare il collettore Malossi al cilindro e fissarlo con la bulloneria originale
- Dove presente, avvitare la sonda lambda sulla boccola filettata saldata sul collettore
- Innestare il terminale Malossi nel collettore interponendo la fascetta stringitubo
- Fissare la staffa di sostegno al telaio utilizzando la bulloneria fornita nel kit come mostrato in figura

N.B. - Controllare il serraggio di tutte le viti

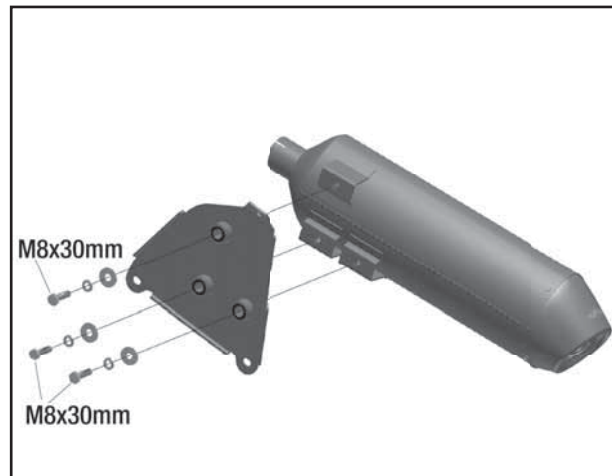
**FITTING INSTRUCTIONS**

- Remove the original exhaust
- Secure the mounting plate to the Malossi silencer as shown in picture below. Use the hardware given in the fitting kit
- Fit Malossi collector to the cylinder and secure it using original hardware
- If needed, plug the oxygen sensor to the plug welded on the collector
- Fit Malossi silencer to the collector, securing it using the hose clip given in the fitting kit
- Secure the mounting plate to the swingarm as shown in picture below. Use the hardware given in the fitting kit

NOTE: Check all the screws to be properly tightened

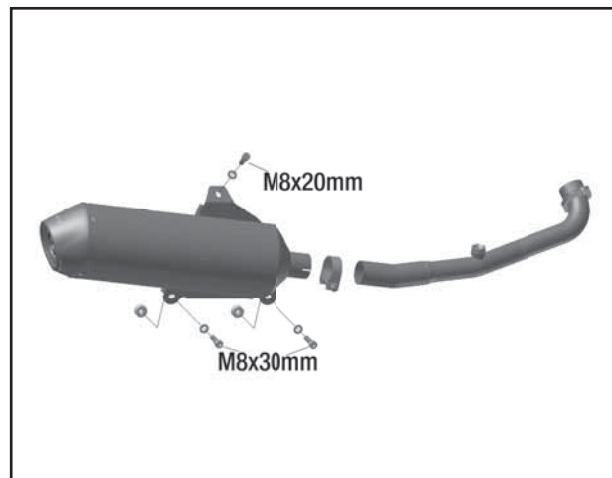
**INSTRUCTIONS DE MONTAGE**

- Enlever le pot d'origine
- Monter l'étrier de support sur le silencieux Malossi en utilisant la boulonnerie fournis dans le kit, comme montré da la figure.
- Si nécessaire fixer même le tampon du béquille avec la boulonnerie fournis dans le kit.
- Connecter la pipe Malossi au cylindre et la fixer avec la boulonnerie d'origine
- S'il y a, visser la sonda lambda sur la douille filetée soudé sur la pipe.
- Insérer le silencieux Malossi dans la pipe en interposant le collier de serrage tuyau.
- Fixer l'étrier de support au châssis en utilisant la boulonnerie fournis dans le kit, comme montré dans la figure.

N.B. - Contrôler le serrage de tous les vis.

AVVERTENZE GENERALI

- Effettuare un controllo del serraggio di tutta la bulloneria dopo una percorrenza di circa 200 km.

MANUTENZIONE

Verificare periodicamente gli attacchi del silenziatore e tutti gli elementi che possono deteriorarsi con l'uso (materiale fonoassorbente, guarnizioni e altre parti in gomma) e provvedere alla loro periodica sostituzione.

GENERAL CARE

- Check all the fasteners after approximately 200 Km.

MAINTENANCE

From time to time, check all the brackets and fasteners, which could be affected by use (sound-deadening material, seals and other rubber parts) and replace them periodically.

NOTICES GENERALES

- Un contrôle du serrage de tous les boulons doit être effectué après 200 km.

MAINTENANCE

Vérifiez périodiquement les fixations du silencieux et tous les éléments susceptibles de s'abîmer avec le temps (matériau de fonoabsorption, joint et autres pièces en caoutchouc) et remplacez-les périodiquement.

Speriamo che lei abbia trovato sufficientemente esaurienti le indicazioni che precedono. Nel caso in cui qualche punto le risultasse poco chiaro, potrà interpellarci per iscritto compilando l'apposito modulo inserito nella sezione "contatti" del ns. sito Internet (www.malossi.com). Ringraziamo fin d'ora per le osservazioni e suggerimenti che vorrà eventualmente farci pervenire. La Malossi si commiata e coglie l'occasione per complimentarsi ulteriormente con Lei ed augurarle un Buon Divertimento. In BOCCA al LUPO e ... alla prossima.

Le descrizioni riportate nella presente pubblicazione, si intendono non impegnative. Malossi si riserva il diritto di apportare modifi che, qualora lo ritenesse necessario, al fi ne di migliorare il prodotto, e non si assume nessuna responsabilità per eventuali errori tipografici e di stampa. La presente pubblicazione sostituisce ed annulla tutte le precedenti riferite agli aggiornamenti trattati.

GARANZIA

Consulta le condizioni relative alla garanzia sul nostro sito www.malossi.com.

Prodotti riservati esclusivamente alle competizioni nei luoghi ad esse destinate secondo le disposizioni delle competenti autorità sportive. Decliniamo ogni responsabilità per l'uso improprio.

We hope you found the above instructions sufficiently clear. However, if any points are not particularly clear, please contact us completing the special form inserted in the "contact" section on our Internet site (www.malossi.com). We thank you in advance for any comments and suggestions you may wish to send us. So goodbye from us all at Malossi, and please accept our compliments. Have Fun. GOOD LUCK and ... see you next time.

The descriptions in this publication are not binding. Malossi reserves the right to make modifications, if it considers them necessary, and does not accept any responsibility for any typographic or printing errors. This publication replaces all previous publications referring to the updating matters contained therein.

WARRANTY

Look up warranty terms in our website www.malossi.com.

These products are reserved solely for races in locations reserved for those purposes and in accordance with the regulations issued by the competent authorities for sports events. We decline any and all responsibility for improper use.

Nous espérons que vous avez trouvé suffisamment claire les indications qui ont précédé. Dans le cas ou certains points ne vous seraient pas clairs, ils vous est possible de nous interpellier en remplissant le module se trouvant dans la section "contact" de notre site internet (www.malossi.com). Nous vous remercions d'avance des éventuelles observations et suggestions que vous voudrez bien nous faire parvenir. Malossi prend maintenant congé et profite de l'occasion pour vous féliciter une fois encore et vous souhaiter un Bon Divertissement. BONNE CHANCE et...à la prochaine!

Les descriptions reportées dans cette publication n'engagent à rien. Malossi se réserve le droit d'apporter toutes les modifications qu'elle jugera nécessaires et décline toute responsabilité pour d'éventuelles coquilles et erreurs d'impression. Cette publication remplace et annule toutes les publications précédentes relatives aux thèmes mis à jour.

GARANTIE

Consultez les conditions relatives à la garantie sur notre site www.malossi.com.

Ces articles sont uniquement destinés aux compétitions dans les lieux qui leur sont réservés, conformément aux dispositions des autorités sportives compétentes. Nous déclinons toute responsabilité en cas d'utilisation abusive.

MINISTERO DEI TRASPORTI E DELLA NAVIGAZIONE
DIREZIONE GENERALE M.C.T.C.
IV Direzione Centrale – Div. 41

RE: Motor vehicles – replacement of exhaust silencer device

This office has received a number of indications from users in relation to the problem of replacement of the exhaust silencer device on motor vehicles. In particular, several of these also relate to the fines applied by police authorities in the event of the device in question being found to be “non-original”, in accordance with Art. 78 of the Highway Code (1) (decree law 30.4.1992, no. 285).

It is well known fact that the exhaust silencer device has a limited life–span when compared to the average life of the vehicle to which it is fitted; so that replacement of this device must be foreseen in order to comply with the noise emission levels indicated in the vehicle’s log–book. **The device can be replaced by a silencer of the same type as the one originally fitted by the manufacturer (it should be remembered that the type of silencer is not indicated in the log–book) or with a replacement silencer that has been approved by the European Union for use in that type of vehicle.**

It is noted that article 76 of the Highway Code (1) is mentioned, which foresees the cases in which inspection and testing by the Offices of the M.C.T.C./CiviI and Hired Transport Authority) is required: in particular, the first paragraph states the following: “...when alterations have been made to the constitutional and functional characteristics, or to the devices fitted to the vehicle and indicated in articles 71 (2) and 72 (3) ...”.

The action of “alteration” mentioned in said article 76 (1) evidently relates to circumstances other than the mere replacement of the original silencer with another of the same type, or with one of an approved type, as mentioned in the foreword, but relates to the real alteration of the physical and mechanical characteristics of the entire exhaust system. This latter circumstance is the only case in which inspection and testing by the Offices of the M.C.T.C. becomes necessary.

Finally, it must be pointed out that the device, even if it is a replacement and of an approved type, must allow the vehicle to conform to the maximum noise levels indicated in the log–book. Compliance with this point is tested by checking the noise level at a distance of 50 cm from the exhaust pipe at a pre–set number of revs, and it can be carried out by the police authorities with ease using a phonometer.

To facilitate identification of original silencers during on–road verification, it must be remembered that these silencers carry the vehicle manufacturer’s name or trade mark, as well as an alphanumeric code. On the other hand an approved replacement silencer carries, as well as the name or trade mark of its manufacturer, an international approval mark, a sample of which is given below:

```
ex 00 0000      |
|               |-----> Approval number
|               |
|               | Identification Code
|               |
|               |-----> for the country in which
|               |
|               |-----> the device was approved
```

The marks described above must be punched onto the elements forming the device itself.

THE CENTRAL MANAGER
Dr. Ing. Tullio D’Ulisse

- (4) See “Highway Code” page 076.00.00 or “Practical Guide to the Motor registration Office”, pages 11.01.00 and 51.03.00
- (5) See “Highway Code” page 071.00.00
- (6) See “Highway Code” page 072.00.00

WARNING: When necessary, the silencer device must be replaced by another one of the same type as the silencer originally fitted by the manufacturer, or by another replacement device approved according to European Union regulations for the same type of vehicle, and bearing, as well as the manufacturer’s name or trade mark, an international production mark: **in both cases there is not need for inspection and testing by the M.C.T.C. Offices in accordance with art. 78 of the Highway Code**, which is only required in the vent of modifications to the device itself.



Art. 3214834

ITALIANO

CERTIFICATO DI OMOLOGAZIONE

Il presente certificato contiene copie dei documenti ufficiali relative all'omologazione del silenziatore di scarico secondo le norme CEE.

ENGLISH

CERTIFICATE OF APPROVAL

This certificate includes copies of the official documents concerning the homologation of an exhaust system according to the ECE regulations.

FRANCAIS

CERTIFICAT D'APPROBATION

Ce certificat comprends les copies des documents officiels qui concernent l'homologation d'un silencieux, selon les dispositions CEE.

DEUTSCH

EG-ABE-GENEHMIGUNG ZERTIFIKAT

Das beiliegende Zertifikat beinhaltet Kopien aus den offiziellen Akten fuer die Eg-Abnahme eines Auspuff-Endtopfes nach den vorgaben der neuen Cee-Norm.

ESPAÑOL

CERTIFICADO DE HOMOLOGACIÓN

El presente certificado contiene copias de los documentos oficiales relativos a la homologación del tubo de escape según normas de la C.E.E.



Référence: e13*97/24*2009/108/9/III/2B*9603*02

Annexes: - Rapport Technique
- Fiche de Renseignements du constructeur

Sandweiler, le 14 juillet 2011

Certificat d'homologation en ce qui concerne un dispositif d'échappement non d'origine pour motorcycle(s)

Component type-approval in respect of a non-original exhaust system for a type of motorcycle

CHAPITRE 9 – ANNEXE III – Appendice 2B

Chapier 9 – Annex III – appendix 2B

Autorité déléguée:

Assigned authority:

Rapport N°:

Report N°:

du service technique:

by technical service:

en date du:

date:

N° du certificat d'homologation:

Component type approval N°:

1. Marque du dispositif:

Make of exhaust:

2. Type du dispositif:

Type of exhaust:

Version:

Version:

3. Nom et adresse du constructeur:

Name and address of manufacturer:

*Société Nationale de Certification et d'Homologation
L-5201 Sandweiler*

LCA 54 0378 007 11

Luxcontrol SA

B.P. 349

L-4004 Esch-sur-Alzette

12.07.2011

e13*97/24*2009/108/9/III/2B*9603*02

Malossi

M10

AL3919, PRI1955_V1, PRI1955_V2, PRI1955_V3,
PRI1955_V4.

Arrow Special Parts S.p.A.
Via Citernese 128/130
I-06016 S. Giustino (PG)

**4. Nom et adresse du mandataire du constructeur
(le cas échéant):**

not applicable

If applicable, name and address of manufacturer's authorized representative:

5. Marque(s) et Type(s) et éventuellement variante(s) et version(s) du (des) véhicule(s) auquel (auxquels) le dispositif est destiné:

Make(s) and type(s) and any variant(s) or version(s) of the vehicle(s) for which the exhaust system is designed:

see page 3 below

6. Dispositif présenté à l'essai le:

23.-24.05.2011

Date system submitted for testing:

7. L'homologation est:

extended

Component type-approval has been:

8. Lieu:

Sandweiler

Place:

9. Date:

14 juillet 2011

Date:

10. Signature:

Signature:

Pour le Ministre des Transports



Marco FELTES
Inspecteur Principal

Pour la SNCH



Claude LIEBSCH
Directeur

Détail des documents joints au dossier et pouvant être obtenus sur demande:

Detail of annexed documents which can be obtained on request:

see: INDEX to TYPE-APPROVAL REPORT

Modifications faisant l'objet de la présente extension:
Modifications of this extension:

refer to Annex A, page 1 of technical report.



Luxcontrol

12.07.2011

Statement

We confirm that the following replacement silencer type M12, produced by Arrow Special Parts S.p.A., is complying with

- the EC-Directive 97/24/EC Chapter 9 regarding permissible sound level and exhaust system

An EC type approval number has been granted by the Luxembourgian Ministry of Sustainable Development and Infrastructure - Transport Division for the following versions of the above mentioned replacement silencer type:

Drawing No.	Marking	Vehicle type	Vehicle Model	Vehicle appr. number
PR1956_V4	e13 0435 9	WVCG 1-1 / 1-2 / 2-1 / 2-4 / 2-5	Suzuki Burgman 400	e9*2002/24*1052

Esch-sur-Alzette,
Your sincerely,

Luxcontrol SA, Type approval department

David Durazzi
Ingénieur inspecteur

Angelo Tomasini
Ingénieur inspecteur

We confirm that the Luxembourgian Ministry of Transport has accepted Luxcontrol SA as a competent testing laboratory with regard to the EC-Directives.



Luxcontrol SA

1, Av. des Terres Rouges
BP 349
L-4004 Esch-sur-Alzette
LUXEMBOURG

Tél. ++352-54,77,11-1
Fax ++352-54,77,11-203
E-mail: info@luxcontrol.com
Int.: www.luxcontrol.com
N° ident.: LU 113 536 61
RC Lux.: B15664

Fortis Banque Luxembourg
IBAN: LU56 0030 1612 0727 0000
BIC: BGLULL
Dexia-BIL
IBAN: LU48 0026 1824 1543 2600
BIC: BILLULL